



Multifunction
voltage and
frequency
monitoring relays
with NFC
technology
PMV95N

Product designation

Product type designation

General characteristics

Description

Minimum and
maximum AC
voltage, minimum
and maximum
frequency, phase
loss, neutral loss,
incorrect phase
sequence and
asymmetry relay

Type of system

Three-phase
with/without
neutral

Power supply

Auxiliary supply voltage U_s Self powered

Operating voltage range 0.7...1.2 U_e

Rated frequency Hz 50/60 $\pm 5\%$

Power consumption Max VA 30

Power dissipation Max W 2.5

Control circuit

Rated voltage to control (U_e)

min VAC 208

Max VAC 240

Voltage set-point ($\%U_e$)

min % 80...95

Max % 105...115

Asymmetry set-point ($\%U_e$)

% 5...15

Frequency set-point ($\%$ rated frequency)

min % 90...99

Max % 101...110

Tripping delay

s 0.1...30

Resetting time

s 0.1...30

Resetting hysteresis

% 1...5

Instantaneous tripping for U_e

Voltage $< 70\% U_e$

Type of reset

Automatic or
manual

Repeat accuracy

% $< \pm 0.1$

Relay outputs

Number of relays Nr. 1

| | | | | |
|---|-----------------------|--------|-----------------|---|
| Relay state | | | | Normally energised De-energises at tripping |
| Contact arrangement | | | | 1 changeover SPDT |
| Rated operational voltage AC (IEC) | | VAC | | 250 |
| Maximum switching voltage | | VAC | | 400 |
| IEC Conventional free air thermal current I _{th} | | A | | 8 |
| UL/CSA and IEC/EN 60947-5-1 designation | | | | B300 |
| Electrical life (with rated load) | | cycles | | 100000 |
| Mechanical life | | cycles | | 30000000 |
| Indications | | | | |
| Indication | | | | 1 green LED for power and 5 red LEDs for tripping |
| Connections | | | | |
| Terminals type | | | | Screw |
| Tightening torque for terminals | | max | Nm | 0.8 |
| | | max | Ibin | 7 |
| Conductor cross section | | | | |
| | AWG/Kcmil | | | |
| | | min | AWG | 24 |
| | | Max | AWG | 12 |
| | IEC | | | |
| | | min | mm ² | 0.2 |
| | | Max | mm ² | 4 |
| Insulations | | | | |
| Rated insulation voltage U _i | | V | | 600 |
| Rated impulse withstand voltage U _{imp} | | kV | | 6 |
| Operating frequency withstand voltage | | kV | | 4 |
| Ambient conditions | | | | |
| Temperature | | | | |
| | Operating temperature | | | |
| | | min | °C | -20 |
| | | max | °C | +60 |
| | Storage temperature | | | |
| | | min | °C | -30 |
| | | max | °C | +80 |
| Housing | | | | |
| Execution (n° of modules) | | | | 2 |
| Material | | | | Self-extinguishing polyamide |
| Mounting | | | | 35mm DIN rail (IEC/EN 60715) |
| IEC degree of protection | | | | IP40 on front; IP20 at terminals |
| Dimensions (W x H x D) | | mm | | 35.8 x 104.7 x 64.9 |
| Weight | | g | | 130 |
| Dimensions | | | | |

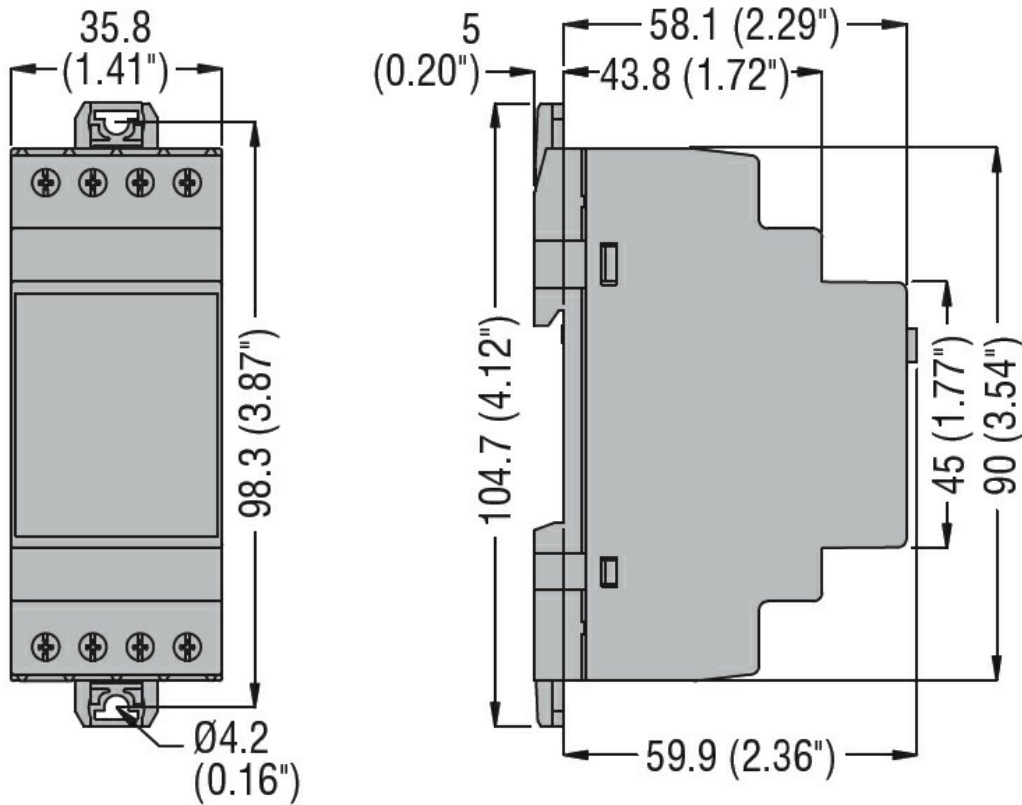

Wiring diagrams

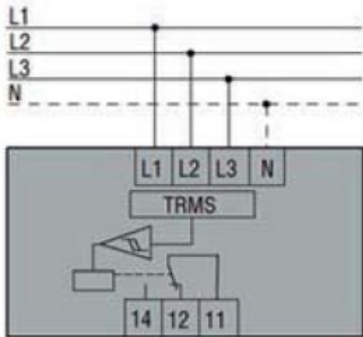

Certifications and compliance

Compliance

CSA C22.2 n°14
IEC/EN 60255-26
IEC/EN 60255-27
UL508

Certificates

cULus
EAC

ETIM classification

ETIM 8.0

EC001438 -
Voltage
monitoring relay